

IsoBOX

SOUND-ABSORBING BOX

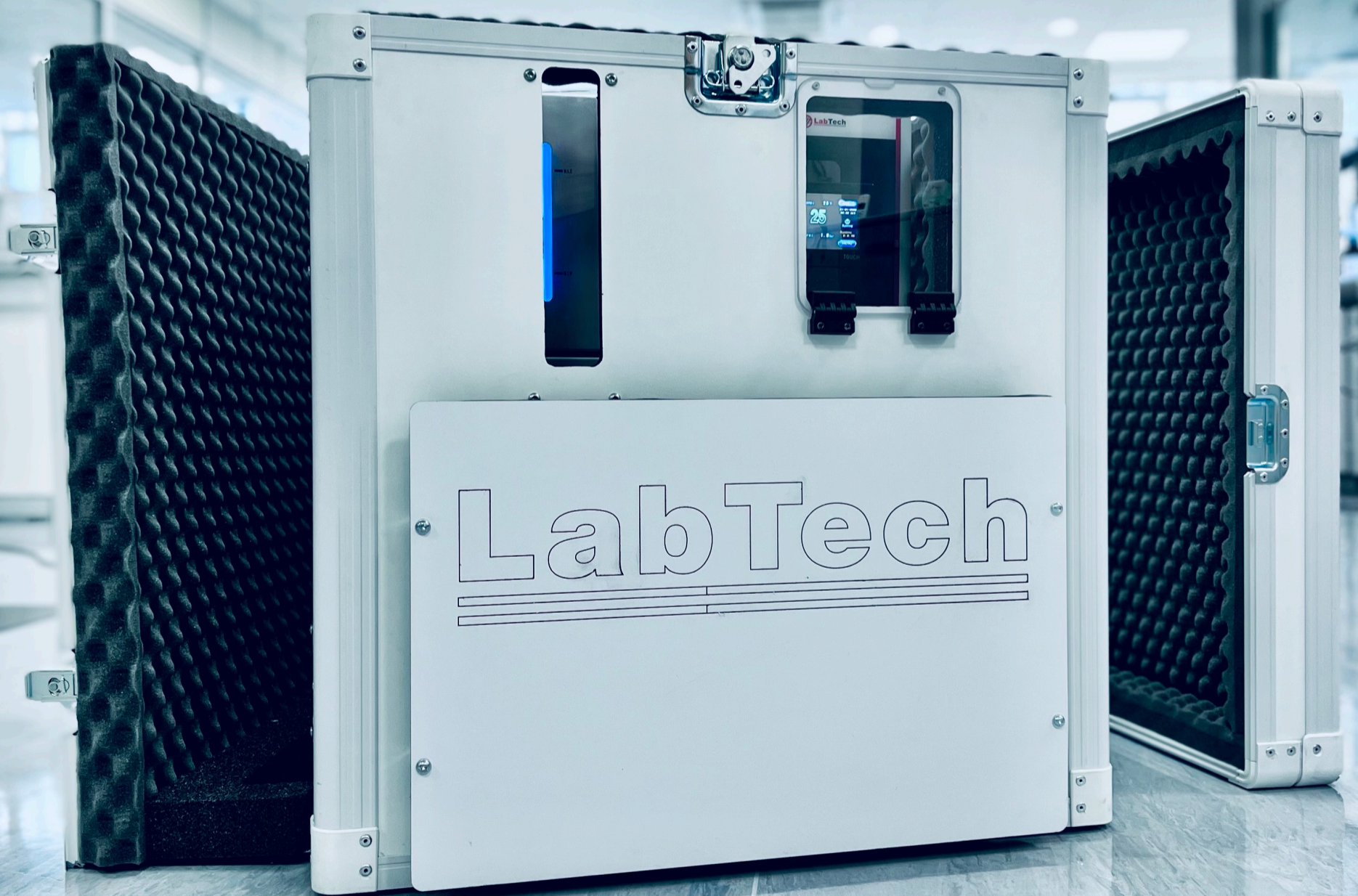

LabTech

WWW.LABTECHSRL.COM

IsoBOX: the sound-absorbing solution by LabTech

The overall **level of noise** in laboratories depends on a number of factors including the instrumentation and equipments used to carry out the tasks of the facility.

High noise levels can lead to a variety of potential **health issues** for laboratory personnel and therefore they are regulated by government agencies. The laboratory manager must then develop strategies to reduce as much as possible the noise level in order to improve the working conditions.

IsoBOX is an innovative product created with high quality **sound-absorbing material** to **reduce the noise level** of the water chiller units or any other smaller equipment that generates high noise level.



What makes IsoBOX unique

IsoBOX has been specially designed to be ready for a quick, fast and easy assembly.

Thanks to the **butterfly latches** it can be disassembled piece by piece according to the needs of chiller access (front, rear, sides).

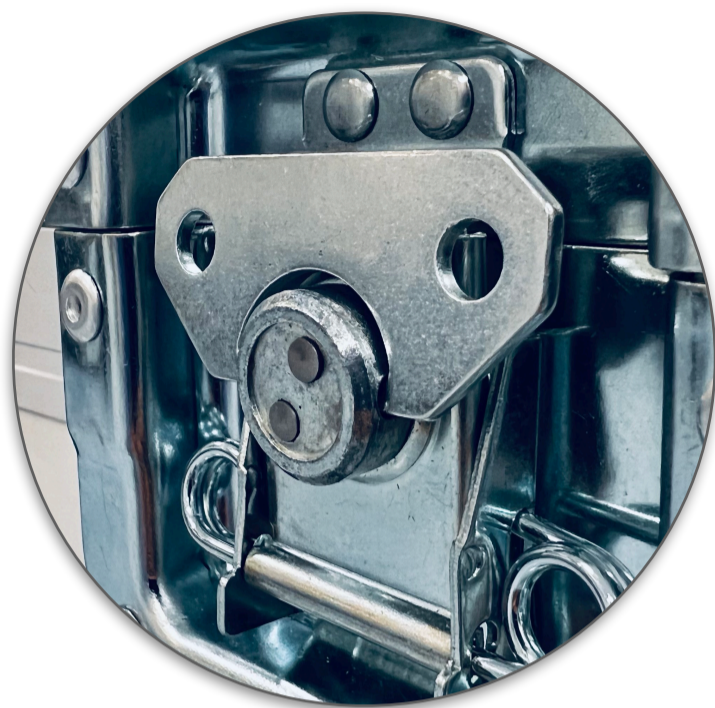

LabTech has developed **IsoBOX** ensuring that the water chiller cooling performances are not affected. LabTech chillers maintain the high efficiency and stable temperature at the maximum heat load thanks to the **six fans** installed on the back of the **IsoBOX**.



IsoBOX allows an **easy access** to the water chiller built-in display and the liquid level indicator.



How the noise is absorbed by IsoBOX

IsoBOX is entirely covered inside with sound-absorbing panels made by high-quality **pyramidal polyurethane material** that is completely self-extinguishing and avoid condensation.



Pyramidal Polyurethane

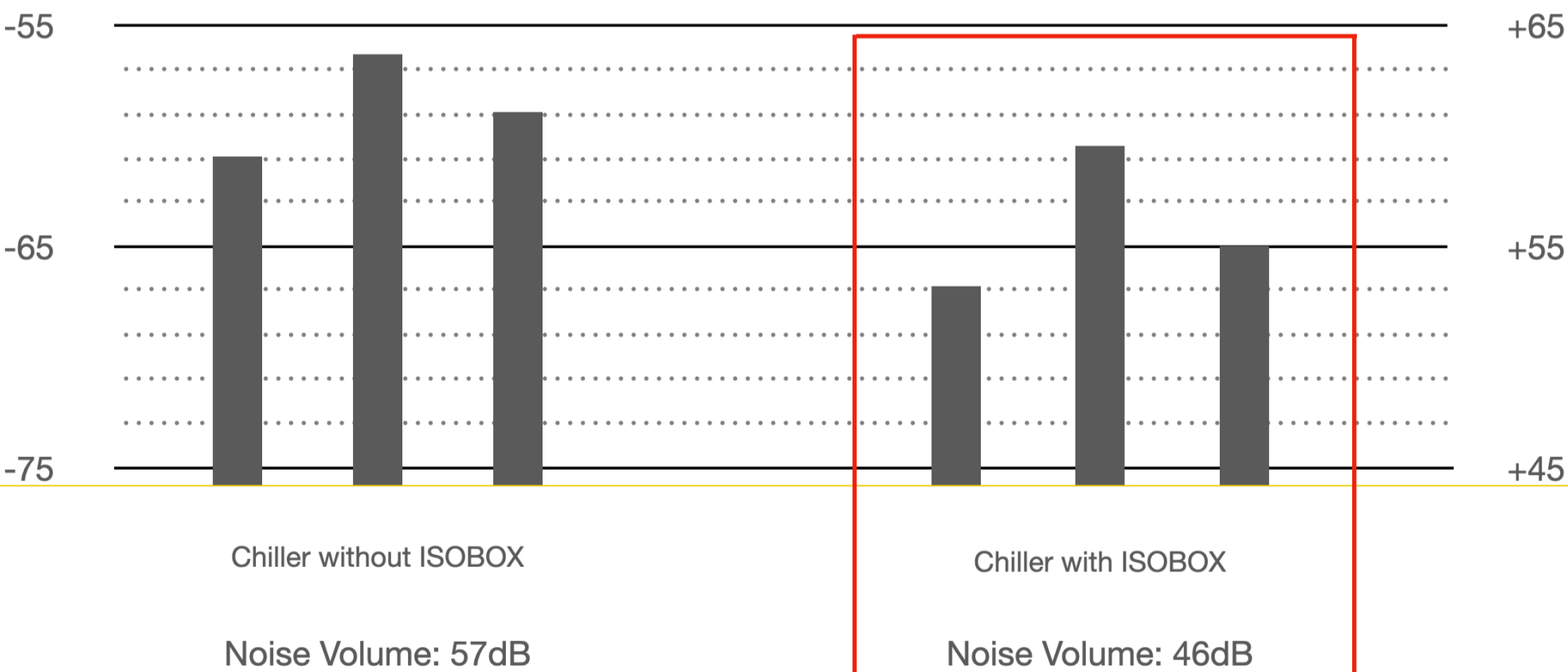

Thanks to the sound-absorbing panels IsoBOX can reduce the noise from 57dB to 46dB

Technical specifications

Required room temperature	No more than 25°C
Dimension (LxWxH cm)	105x73x83
Weight (Kg)	50
Power supply voltage	230V 50/60Hz
Safety	Self-extinguish materials
Fans air supply (m ³ /h)	1100
Power supply (W)	140W
Ordering information	LW-ISOBX21/30

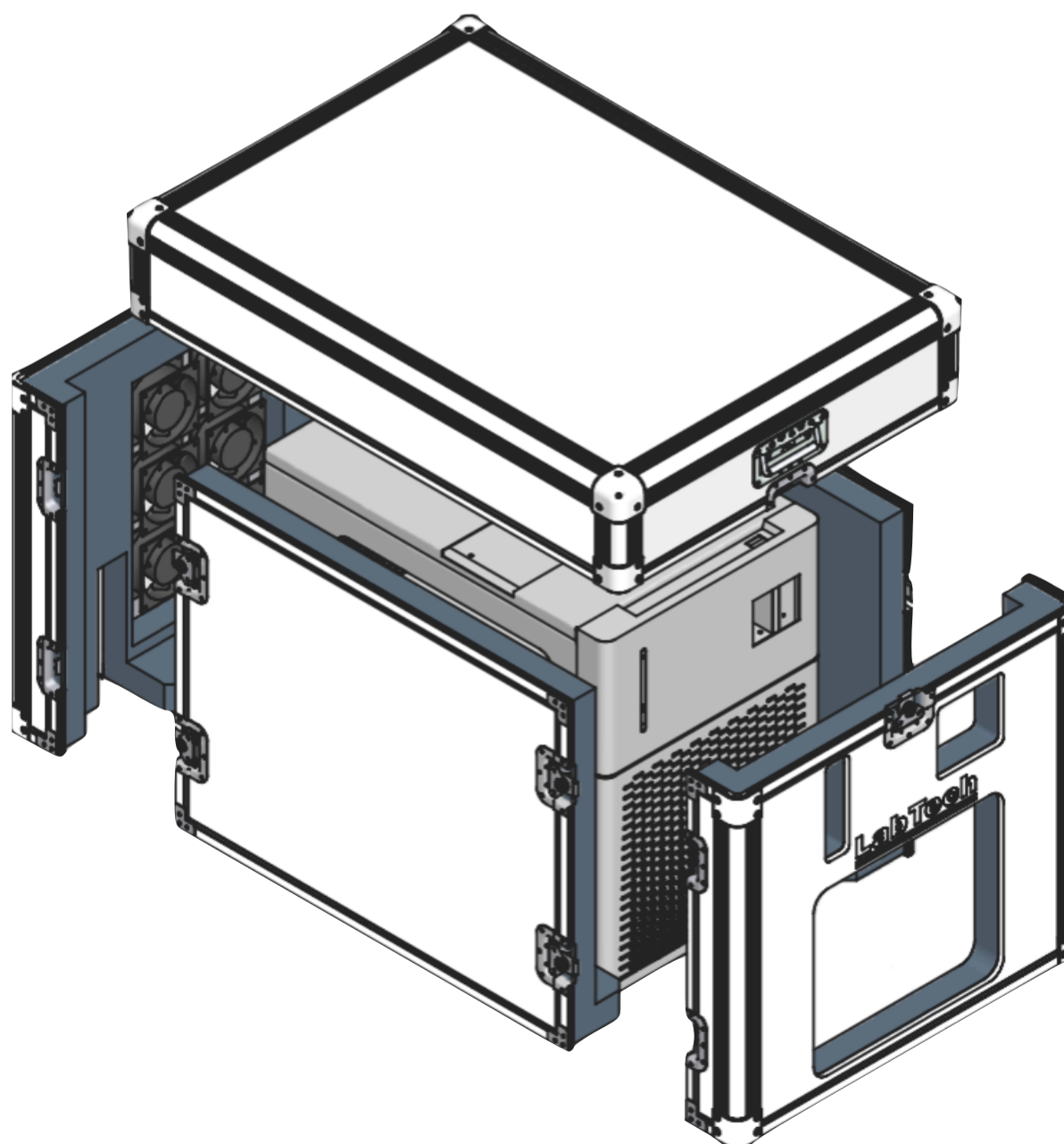

LabTech

WWW.LABTECHSRL.COM

LabTech, your reliable laboratory solution provider.

LabTech is a leading manufacturing company with skill and passion devoted to provide advanced laboratory solutions to the analytical community. We are located in Sorisole, northern Italy, with facilities in USA and China. Incorporated with global branches, LabTech is organized into R&D, production, marketing & sales and customer support. Major LabTech products include organic/inorganic sample preparation systems, laboratory cooling/heating/temperature control equipments, analytical instruments, gas generators, laboratory centrifuges and liquid nitrogen generators. With knowledgeable scientists and experienced engineers, our R&D team has developed and released a series of new lab equipments and instruments dedicated to the modern analytical laboratories. With all of these accomplishments and our endless research and development efforts, we are proud to be your professional partner in lab solutions.



LabTech Srl

Via Fatebenefratelli, 1/5 - 24010 Sorisole (BG) - Italy

Tel: +39 035 576614

www.labtechsrl.com - email: marketing@labtechsrl.com